

Project Title

Development of a transparent medical mask (ViewMask) to enhance (healthcare worker) HCW-patient communication

Project Lead and Members

Project lead: Florence Tang Mei Ai, Senior Speech Therapist, TTSH

Project members: Dr Brenda Ang Sze Peng

Organisation(s) Involved

Tan Tock Seng Hospital, Lee Kong Chian School of Medicine

Healthcare Family Group(s) Involved in this Project

Medical, Allied Health, Nursing

Applicable Specialty or Discipline

Speech Therapy, Nursing, Otorhinolaryngology, Infection Control

Project Period

Start date: 01 Dec 2020

Completed date: 30 Nov 2022

Aims

1. To evaluate current transparent face masks where commercially available
2. To innovate and design prototypes of a medical grade surgical mask with a 'see-through' window that will meet local needs and established performance/safety standards
3. To collaborate with a local mask manufacturer to produce the mask
4. To evaluate the mask from end-users' and clients' perspectives in clinical and non-clinical environments

Background

During the initial phases of the COVID-19 pandemic, the wearing of facemasks was required for the general population in Singapore. The current 'new normal' mandates mask wearing in healthcare settings and on public transport. Face masks obscure the lower half of the face, limiting visual cues from lip movements and facial expression. As these non-auditory cues can accentuate speech understanding, mask wearing can make communication especially difficult for communication-vulnerable persons such as those with hearing loss. A paradigm shift for medical masks to include a “see-through” window should help to overcome this issue. It is vital that this redesigned mask should meet existing HSA standards for respiratory protection against droplets, bacterial filtration efficiency $\geq 95\%$ and all other safety and performance requirements. Additionally, the clear window must be fog resistant whilst maintaining breathability. While there were commercially available clear mask options, none of the companies was shipping their masks to Singapore. There was also no medical-grade clear mask meeting the HSA standard.

Methods

1. We worked with Racer Technologies to develop prototypes of the 'see-through' medical-grade surgical mask (i.e., ViewMask)
2. Each prototype was tested in clinical and non-clinical settings where surveys were collected from healthcare workers and patients
3. New iterations were designed based on the survey findings, which included quantitative and qualitative responses
4. In total, five ViewMask prototype iterations were created and trialed over the 2-year period. The final ViewMask prototype (VM5) is pending clinical testing and HSA approval

Results

Evaluation of prototype iterations was done both within and outside of TTSH during the pandemic period. Necessary changes to test locations were made in accordance to

then evolving safe management measures. For example, VM2 and VM3 could not be tested in TTSH due to a tightening of mask wearing rules for all frontline HCWs (requiring a minimum of N95).

Prototype version	Test location(s)	Group 1*	Group 2**
VM1	TTSH	81	48
VM2	Brahm Centre, Tzu Chi Clinic	54	44
VM3	Mayflower Pri. Sch., Beatty Sec. Sch., Cerebral Palsy Alliance S'pore (CPAS)	42	18
VM4	TTSH	49	31
Total subject		226	141
*Group 1: healthcare workers, VWO workers, teachers who <u>wore</u> the prototype masks for at least 1 hour during their work			
**Group 2: patients, care recipients, caregivers who <u>interacted</u> with Group 1 subjects over the prototype masks. Students' feedbacks were not collected as they were minors.			

To evaluate prototype iterations, we have collaborated with several Voluntary Welfare Organisations (VWO) that provide community services, as well as MOE schools. Their staff and volunteers provide a variety of services where good communication and relationship are no less essential between care-providers and care-recipients. Prototype evaluation was carried out amongst their staff, volunteers and care recipients and other clients, in non-healthcare settings.

Our evaluation from both end-users and clients' perspectives had focused on comfort, breathability, clarity of window, durability, and acceptance. Finally, the effectiveness of prototype mask to improve communication in both clinical and non-clinical environment was also part of the evaluation. Data is currently being analysed by our biostatistician to help us answer the following hypotheses:

Hypotheses:

1. Medical mask with a transparent component provides more visual information than conventional surgical masks
2. Medical mask with a transparent component improves the quality of communication in healthcare environment

3. Both end users and their clients will appreciate the benefits and accept the usage of these masks

By the end of this study, our team had gone through 4 rounds of prototype design and evaluation to arrive at a final 5th version (see attached diagram and technical disclosure of ViewMask for details). As the ASTM certification cost is considerable, this process will only be carried out with this final version. Our industry collaborator, Racer Tech is currently working with their partner lab to schedule a test slot for the prototype mask.

Unfortunately, towards the end of this study, ViewMask's novelty and inventiveness was deemed to be low by the grantor after patent examination, and hence patent filing was not supported. This was also likely due to other competing transparent mask available in the market, and a change in public's perception on the threat of COVID19 which has reduced considerably over time. Grantor has decided to retain this IP as a "know-how".

Additionally, due to delays by the vendor and the lab testing facility, a quotation for lab tests was only obtained in February 2023, which was beyond the cut off for the grant funding period. Thus, we were not able to complete the lab tests for the project.

Lessons Learnt

Challenges

1. Ever-changing COVID-19 requirements:

The ever-changing COVID-19 requirements made mask testing challenging and introduced multiple delays. At the height of the COVID-19 pandemic, many of our test sites required higher filtration masks, which did not include surgical masks like ViewMask. The team collaborated with external parties and found alternative populations to trial the mask with.

2. Dispersed teams, change of PI due to staff movement:

Due to the COVID-19 situation, our team had to find other ways to meet e.g., through Zoom and intensify the communications so we could continue with our innovation journeys. We also had to navigate changes in the team make-up over the 2-year period.

3. Important to stay nimble during product development phase:

In our case, we have definitely sensed some level of incompatibility between the industry's demand and the current way we conduct clinical research, where in the industry, speed is everything in order to be the first to come up with a market-compatible product. The amount of 'red-tape' our team had to navigate during this study (lengthy reviews and approvals required for each protocol amendments by the ethics committee and MMD's reviews and approvals of purchasing important research materials) may require a lot of streamlining to keep up with the industry's requirement. The opportunity cost was huge where due to the prolonged product development, multiple iterations, and testing, we were not able to roll out a certified and usable mask before the end of the pandemic. Now that Singapore has returned to near-normal and mask wearing is optional in most settings, there is a lower demand for these types of masks, which may impact companies' willingness to continue the commercialization process.

4. Important to consider provisional patent-filing as early as possible:

One thing we've learnt from our industry partner was they would normally try to secure the 'date-of-filing' via a provisional application with iPOS (valid for 12 months) as soon as possible once a potential product idea was formed. Our team put up an application one back on 05 Mar 2021 when the idea of foldable transparent window was first mooted. However, the opportunity cost as elaborated earlier due to the prolonged product development cycle/clinical testing has caused this filing to lapse.

5. Prepare for delays with various partners

As we were wrapping up the project, we did not account for possible further delays in the laboratory testing process. We had begun negotiating with our partner as early as

September 2022 for the quotation, and were of the impression that it would be completed by the November 2022 deadline. However, it was only in February 2023 that our partner reverted with the quotation for laboratory testing. Thus, we were not able to complete the trials.

Good Practice:

1. Thorough planning and evaluation were undertaken throughout the course of the project. The project team consistently obtained detailed feedback from end-users, which was used to improve the next mask iteration.
2. Innovative solutions were prototyped and explored throughout the phases of development. The team continued trying and troubleshooting mask designs e.g., turning the folds inside out, incorporating creases in the transparent sheet to improve moldability to the face.

Conclusion

Our team was able to work well with our external partners to complete the innovation, development, testing and refinement of a transparent medical-grade surgical mask. The final prototype will need further laboratory testing prior to eventual commercialization.

Additional Information

The project aimed to develop a transparent, disposable surgical mask to help improve communication effectiveness while maintaining infection control standards. The target users are persons who communicate with individuals such as the deaf, hard-of-hearing and those with communication difficulties.

Impact of our research:

Face masks having a transparent portion over the mouth area of the wearer, such as ViewMask promote better communication between the speech generator (i.e., wearer) and the speech recipients (e.g., patients). The use of redesigned face masks benefits patients by reducing anxiety, improve conveyance of empathy from the carers and

improves care delivery, all while being protected from pathogenic contaminants (e.g., bacteria and viruses) and particulates. Nonetheless, there exists a need for face masks that can (a) provide customizability for improved wearing comfort; (b) are low cost and not resource-intensive to manufacture to drive availability and use, (c) continue to provide an effective barrier to air-borne pathogens; and (d) provide improved communication between service providers and their clients through enhanced visibility of the lower face and mouth.

Project Category

Technology

Prototyping Resources, Product Development, Commercialisation, Proof of Value, Product Evaluation, Safety Evaluation

Keywords

COVID-19, Face Mask, Non-Auditory Communications

Name and Email of Project Contact Person(s)

Name: Florene Tang

Email: florence_ma_tang@ttsh.com.sg

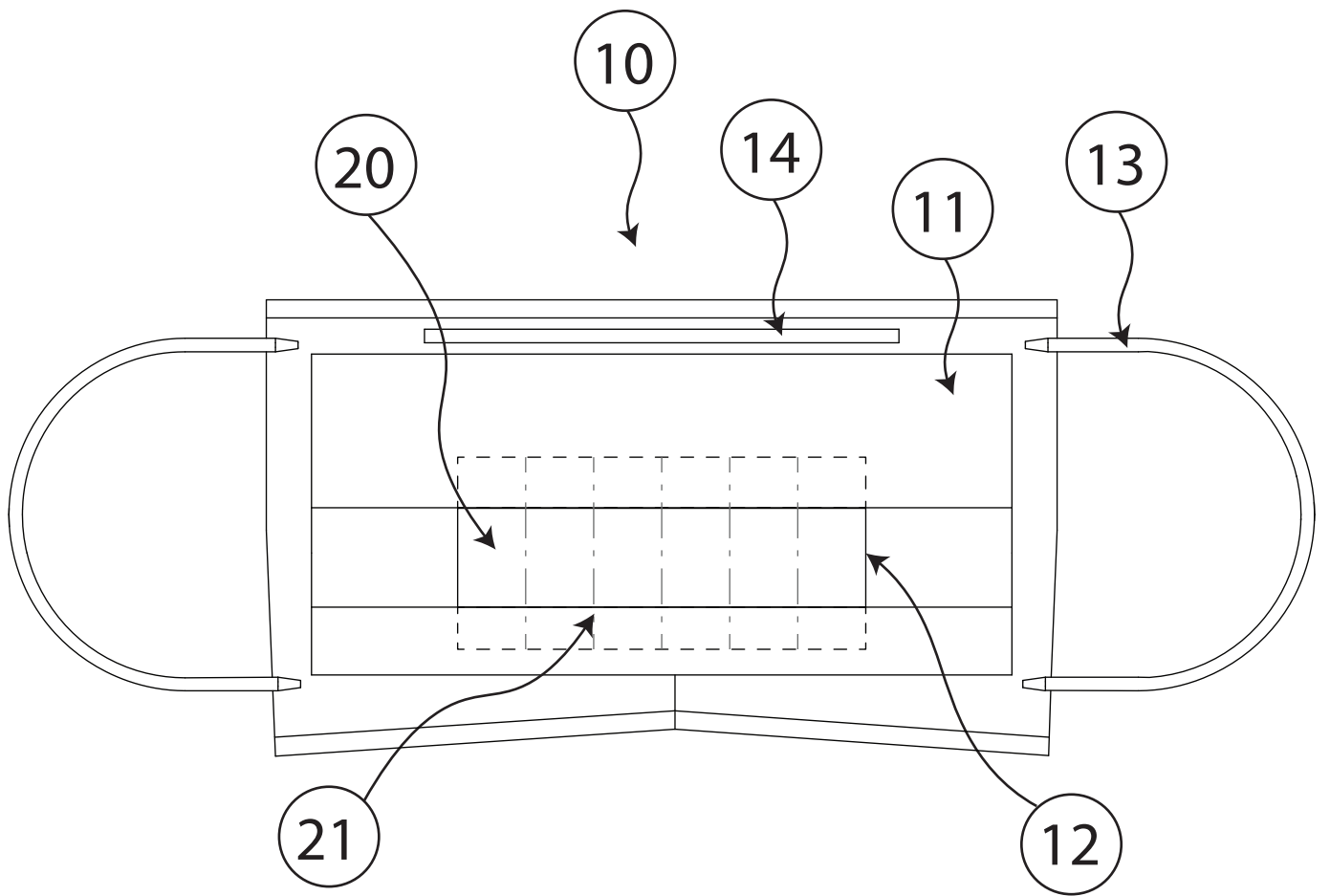

FIG. 1

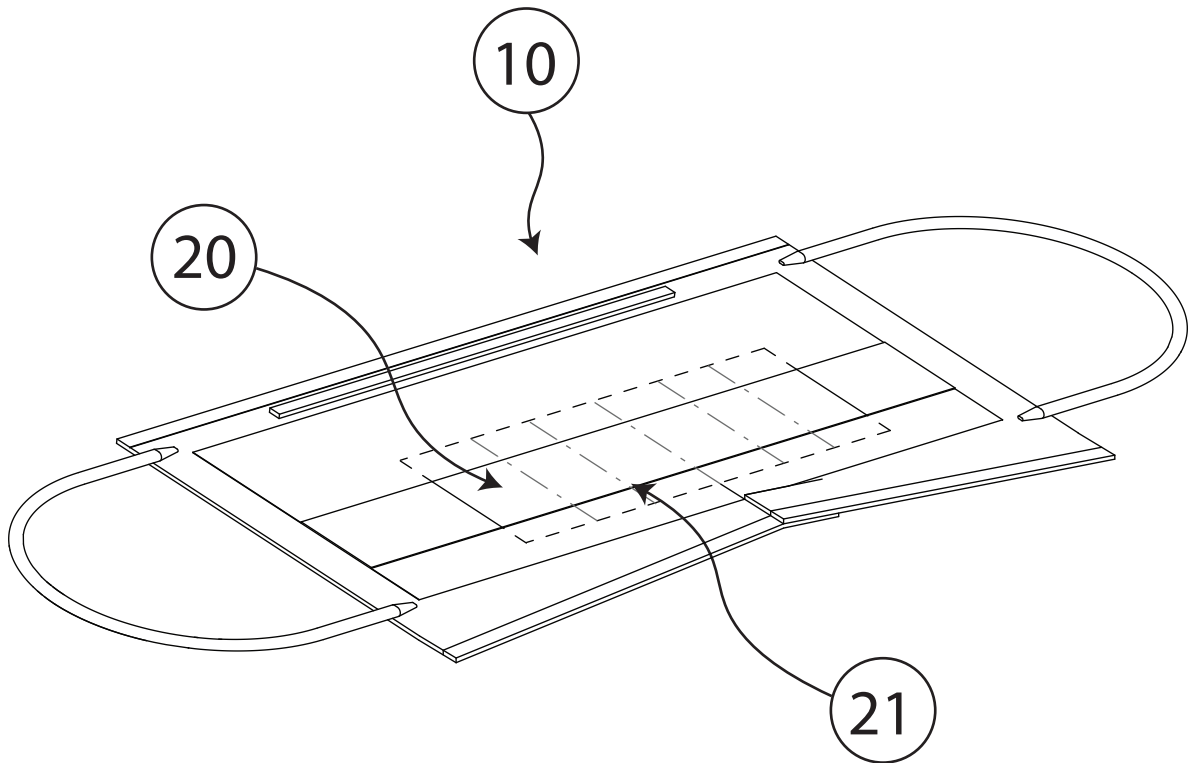

FIG. 2

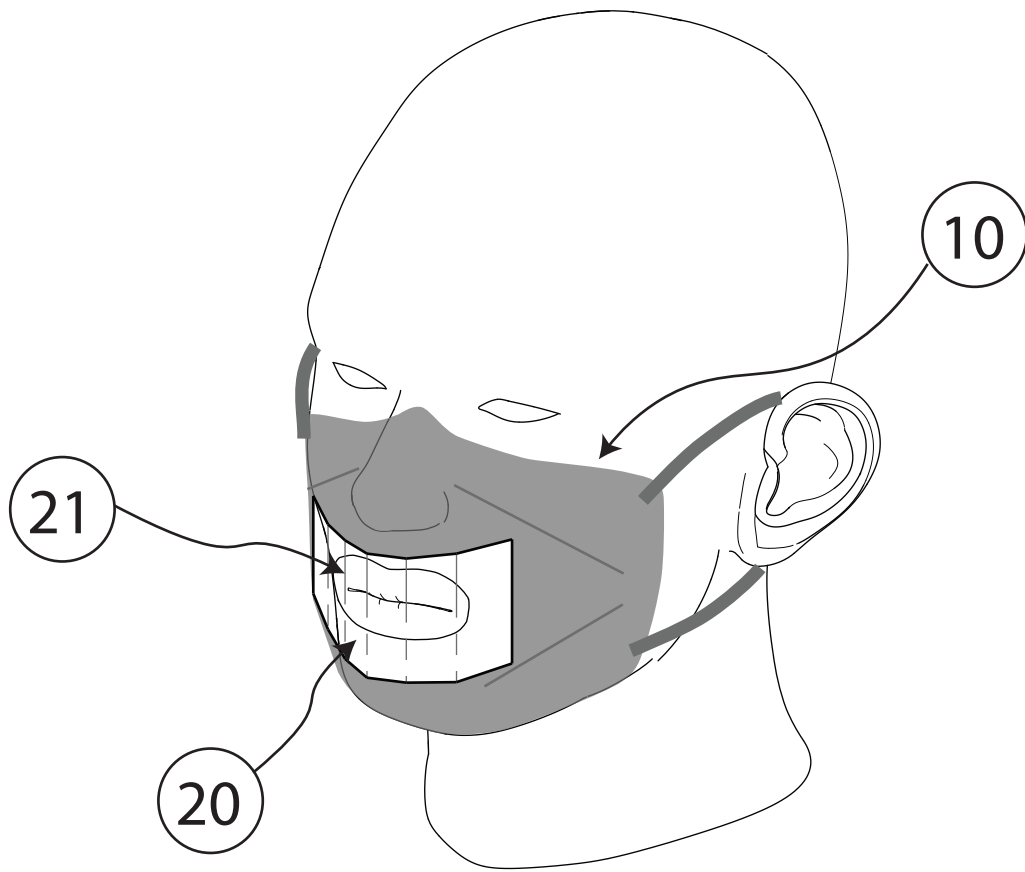

FIG. 3

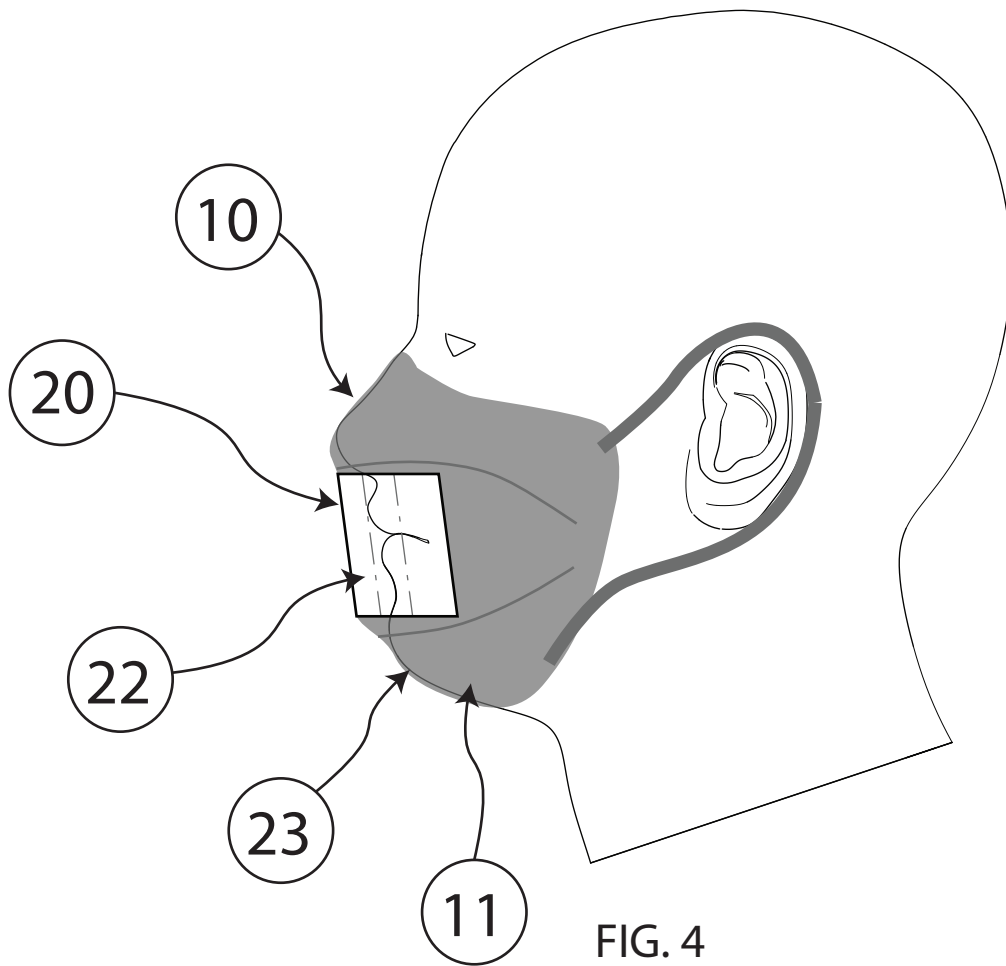

FIG. 4